

ZAWES



Model:S3

USER MANUAL

Thank you for purchasing ZAWES Electric dirt bike,we will provide you with better products and better service!

Contents

1 Disclaimer	1
2 Packing List	2
3 Parts Information	3
4 Instrument introduction	5
5 Assembly Procedure	6
6 Charging Steps	7
7 Safety Instructions	11
8 Riding Operation	11
9 Specifications	12
10 Warranty	13
11 Contact Information	14

1 Disclaimer

1. Under no circumstances, including but not limited to negligence, shall we be liable for any special or indirect damages resulting from the failure to use the materials in this manual, even if we have been advised of the possibility of such damages.

2. When using this product, please comply with the laws and regulations of your region. We shall not be responsible for any claims, liabilities, or losses arising from, or that may arise from, the consumer's violation of local laws and regulations.

3. Warning: Charging lithium batteries may be dangerous. Please charge them outdoors.

2 Packing List

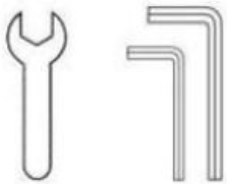

Tool*1

ZAWES



Model:S3

USER MANUAL

Manual*1

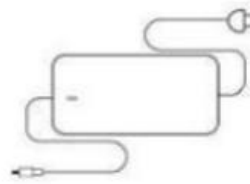

Charger*1



Package*1

- 1.Carefully check package contents,if anything is missing or damaged,please contact our customer service for support:support@zawes.com.
- 2.After verifying that all components are present and in good condition,you can assemble your new Electric scooter.
- 3.Please retain the box and packaging materials in case you need to ship your Electric scooter in the future.
- 4.Remember to power off your Electric scooter and unplug the charging cable before assembling,Mounting accessories,or cleaning the mainframe.
- 5.Always use both an electronic brake and a foot brake for emergency stops.Otherwise,you risk falls or collisions from not achieving the max braking capability.

***The picture is for reference only.Please refer to the actual product for more**

3 Parts Information

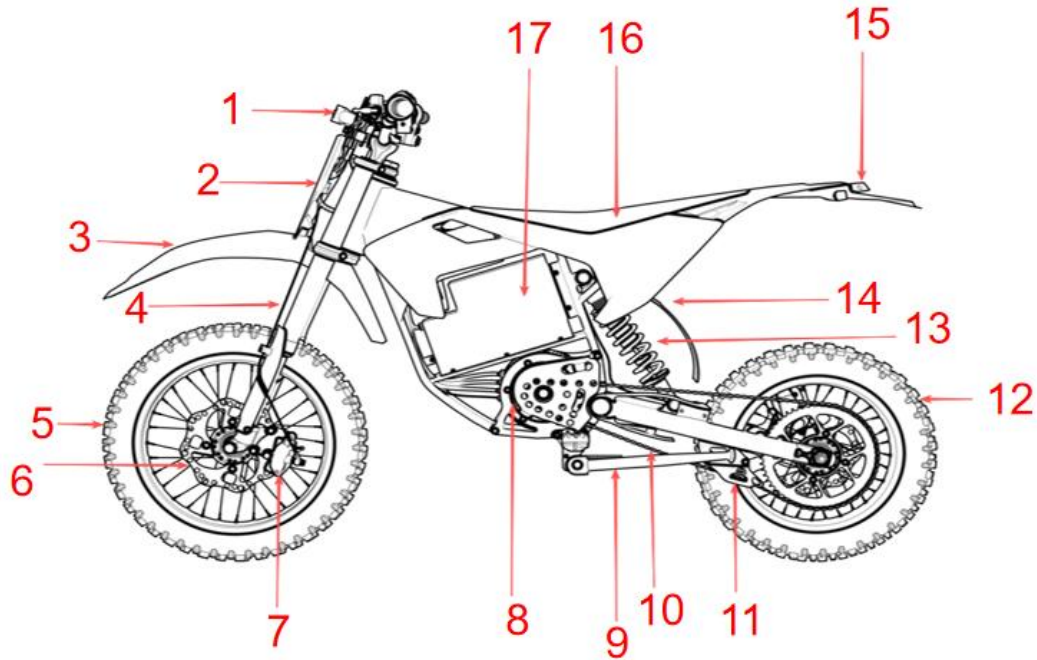

1 Headlight

2 Head Badge

3 Front Fender

4 Front suspension

5 Front Wheel

6 Brake Pads

7 Brake Caliper

8 Mid-drive Motor

9 Kickstand

10 Chain

11 Chain guide

12 Rear Wheel

13 Rear Suspension

14 Rear Fender

15 Taillight

16 Saddle

17 Battery

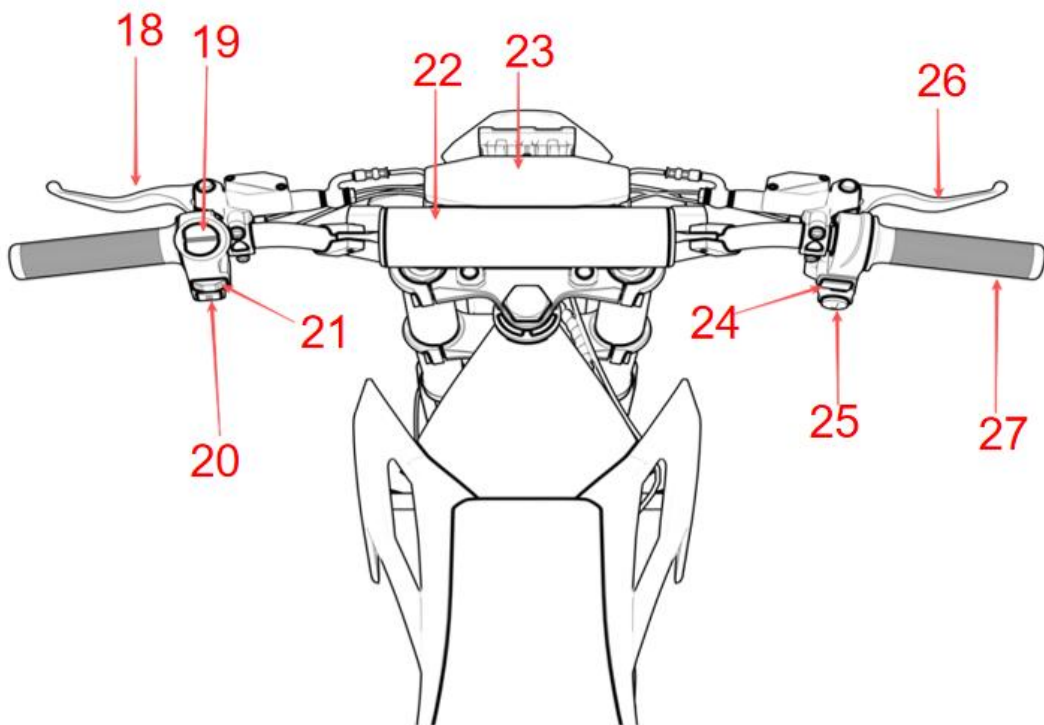

18 Rear brake lever

20 Horn switch

22 Handlebar Pad

24 Mode switch

26 front brake lever

19 Headlight switch

21 turn signal light switch

23 Display

25 Keyhole

4 Instrument introduction

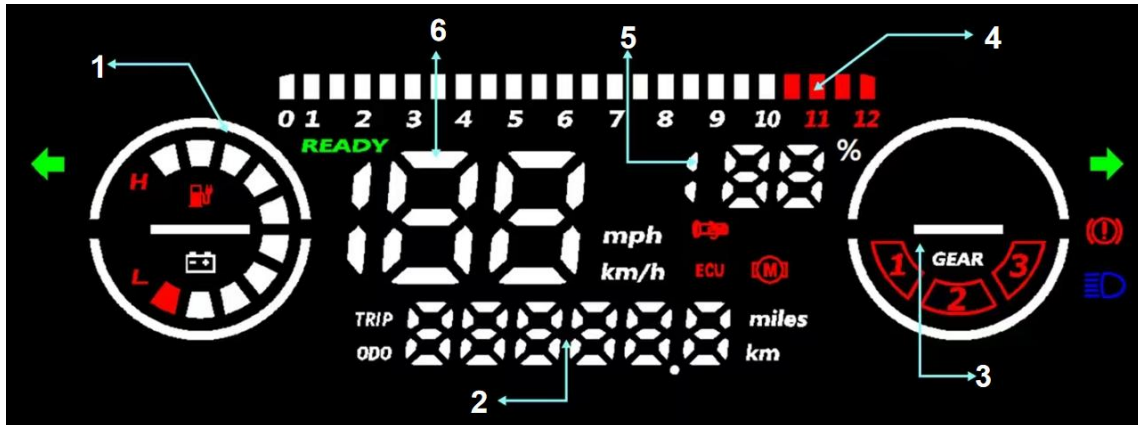

1. Battery level display area (Each segment represents 10% of the battery) .

2. Mileage display area.

3. Gear display area (Gears 1 to 3 are switchable) .

4. Throttle level display area.

5. Voltage display area.

6. Actual speed display area.

Turn Left	Turn right	Barking	Headlight	Self-Test Completed	Throttle Malfunction
Motor Malfunction	Controller Malfunction	Brake Light Warning	Fully Charged	Low Battery	

5 Assembly Procedure

I Complete Wiring Assembly

Important Notice:The connectors of the wiring terminals must be aligned, as shown in the figure on the right.



Electrical Wiring Overview:



Specific Wiring Diagram:

Brake taillight: Red connector, 2-pin, no left/right distinction.



Twist throttle: Black connector, 6-pin.



Front headlight: Yellow connector, 3-pin.



Display: Purple connector, 7-pin.



Control buttons: Black connector, 6-pin.



Brake: Red connector, 2-pin.



Left & right turn signals: Red connector, 2-pin, left and right are distinguished.



Wiring Completed Diagram:

II Full Bike Assembly

A. Installed the handlebar

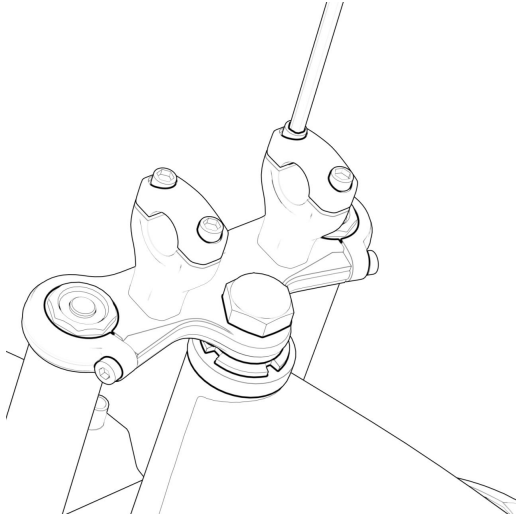

Use an Allen key to loosen the handlebar clamp bolts.

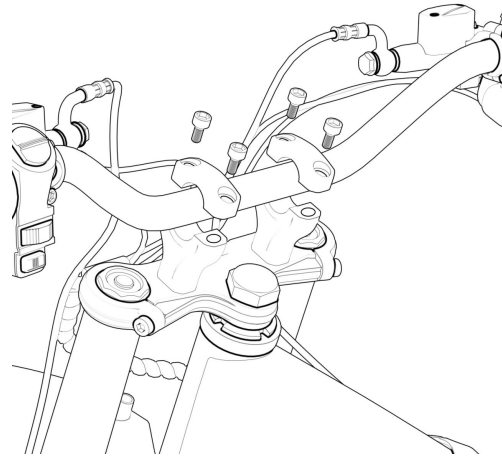

After adjusting the handlebar angle and left - right position, tighten the four clamp bolts securely.

B. Installed the display

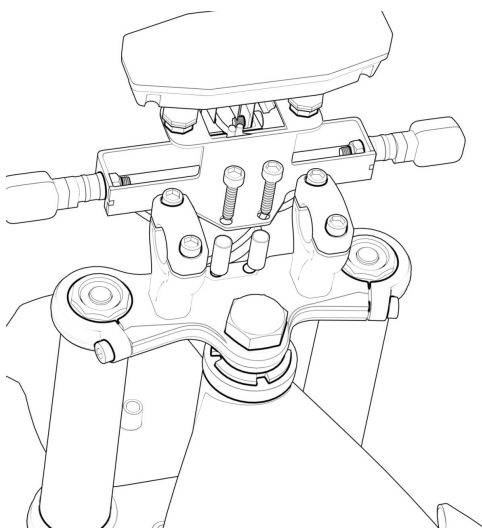

Place the display bracket onto the sleeve, then insert the bolts through the bracket holes and the sleeve.

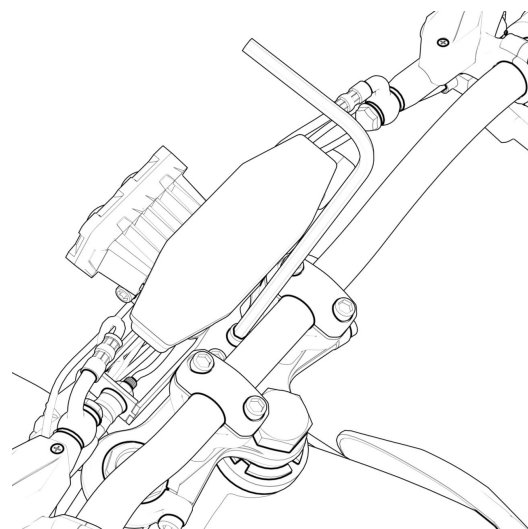

Use an Allen key to tighten the bolts.

C. Installed the front fender

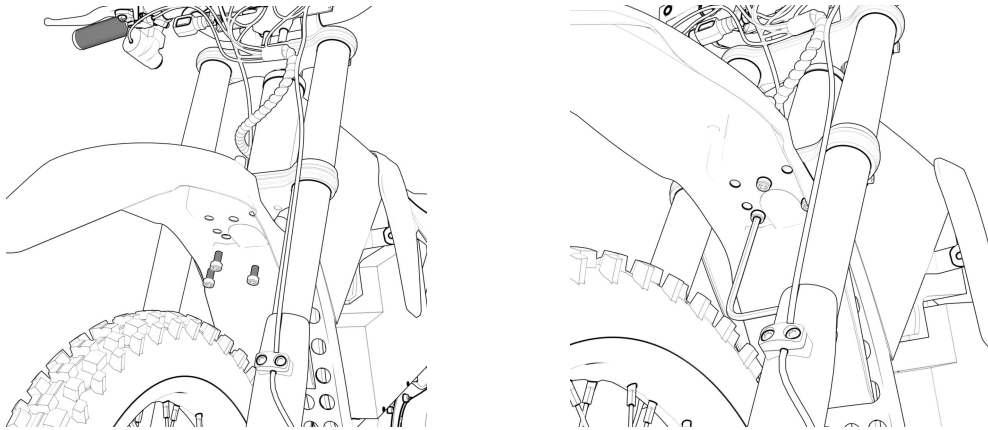

There are a total of three bolts in this step—use the correctly sized Allen key to tighten all of them.

D. Assemble the Front Brake Caliper

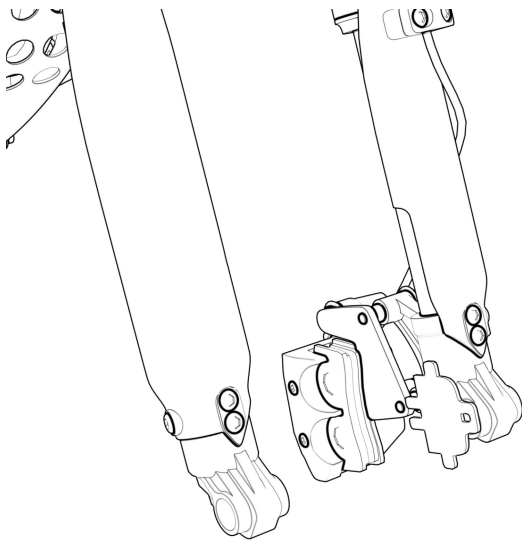

Note: This step must be completed before installing the front wheel. The brake caliper has two pin holes. Align them with the corresponding positions, insert the pins, and tighten the bolts.

E. Installed the front wheel

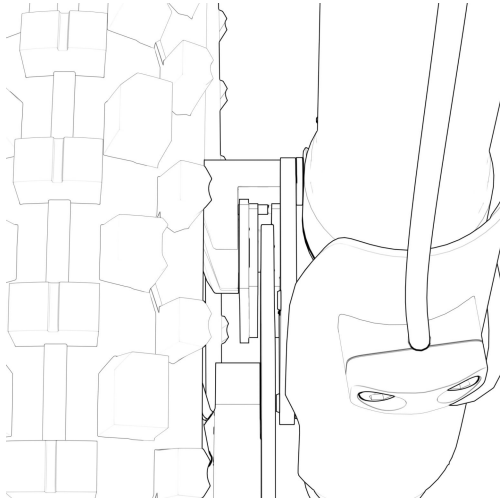

Insert the brake disc of the wheel into the caliper pistons.

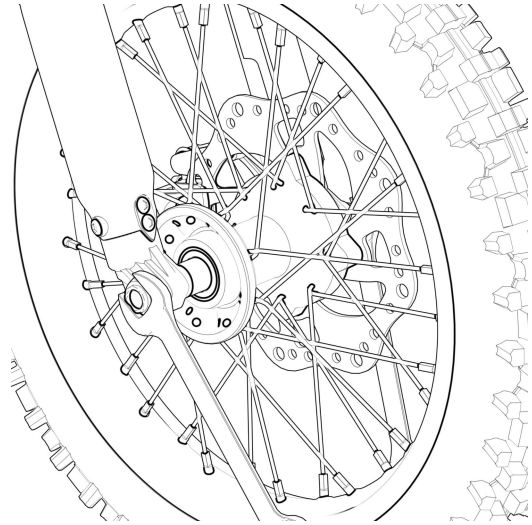

Secure the corresponding sleeve, insert the wheel axle, then use an open-end wrench to tighten the axle nut.

F. Installed the rear shock

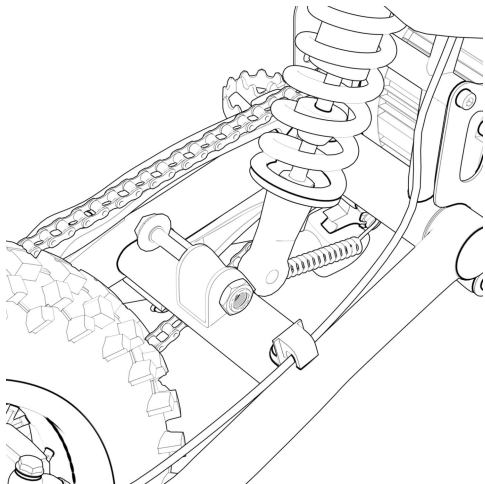

Use an open-end wrench to loosen the rear shock mounting bolt.

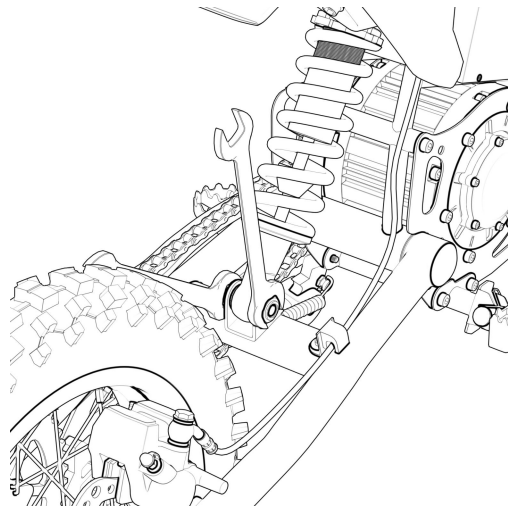

Insert the bolt through the rear shock eyelet, then use an open-end wrench to tighten the nut.

G.Installed the front plate



Place the number plate onto the sleeve, insert the bolt through the number plate and the sleeve

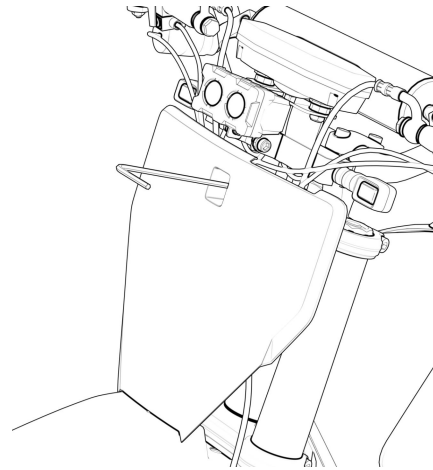

and tighten it with an Allen key.

6 Charging Steps

Open the rubber cover of the charging port and insert the charging plug.

When the charger indicator light turns red, charging is in progress.

When the indicator light turns green, the battery is fully charged.

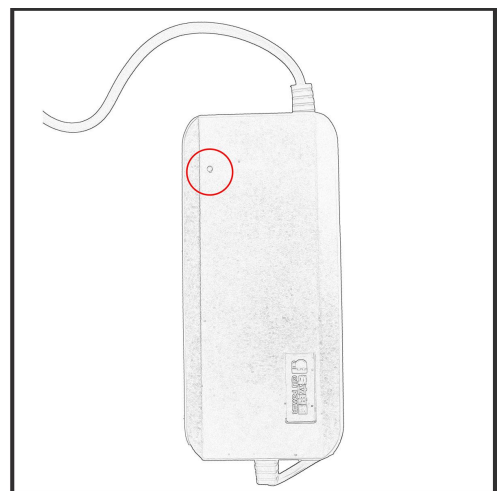
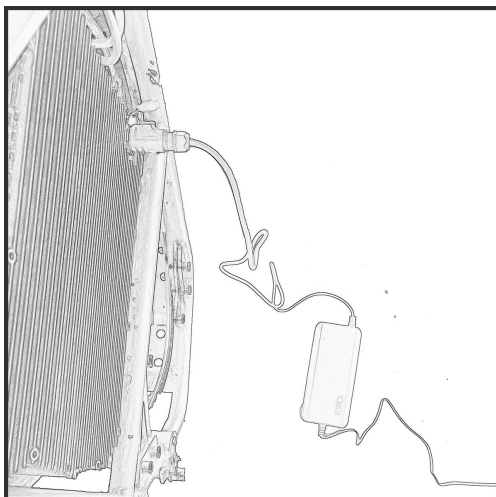

7 Safety Instructions

1. Follow all local traffic laws and regulations while riding.
2. Always wear a safety helmet and ride responsibly.
3. Before riding, check and ensure that all fasteners are tight and no parts are damaged.
4. If the motorcycle makes any unusual noise or alarm sound, stop riding immediately.
5. Charge the battery regularly to prevent complete discharge. A fully depleted battery may cause permanent damage.
6. Do not use unauthorized third-party chargers.
7. Do not use non-original or third-party batteries, as this may pose safety risks.

8 Riding Operation

Always perform a pre-ride check to ensure safe riding. Before riding, please inspect the following to ensure your safety:

1. Brakes

Make sure the braking system operates smoothly. Ensure that the power is cut off during braking and that the brakes respond promptly to stop the wheels.

2. Display Screen

Verify that the screen displays correctly, no warning lights are on, and check the remaining battery level.

3.Tires

Ensure the wheels rotate smoothly and that the tire pressure is within the recommended range.

4.Component Connections

Carefully inspect the motorcycle for cracks, damage, or loose parts. Repair or replace any issues before riding.

9 Specifications

S3 Parameter Table		
Items	Type	Parameter
Size	Unfolded (Length*Width*Height)	1530*710*910mm
	Package Size(Length*Width*Height)	1320*340*665mm
Weight	Net Weight	53kg
	Gross Weight	61kg
User	Load	120kg
	Recommended Age	12+
Performance	Max Speed	70km/h
	Max range	60-70km
	Max Climbing angle	35°
	Operating Temperature	40°C
	IP Rating	IPX4

S3 Parameter Table		
Items	Type	Parameter
Battery	Voltage	60v
	Max.Charging Voltage	67.4v
	Capacity	23.4Ah
Motor	Peak power	5kw
	Input Voltage	60v
Charger	Output Voltage	67.4v
	Output Current	2A
	Charging Time	12h

10 Warranty

The motorcycle is covered by a one-year warranty from the date of purchase. The warranty does not cover the following situations:

1. Consumable and wear-prone parts, such as tires, brakes, and plastic components.
2. Damage caused by improper use or failure to follow the user manual.
3. Damage resulting from accidents, scratches, or exposure to corrosive substances.

4. Damage caused by unauthorized use of third-party accessories or modifications.

11 Contact Information

